



⚠ WARNING/AVERTISSEMENT

Read this manual before installation and use.

Lisez ce manuel avant l'installation et l'utilisation.

Required Tools (327 Model Only)

	5/32" Allen Wrench
---	--------------------

Optional Tools (327 Model Only)

	3/16" Allen Wrench	Awl or other sharp instrument
	Phillips Screwdriver	

This manual is for the following part numbers

PART NUMBER	DESCRIPTION
325-XX-XXX	Stool, Pneumatic Foot Operated w/o Backrest
326-XX-XXX	Stool, Pneumatic Foot Operated w/Ergo Backrest
327-XX-XXX	Stool, Pneumatic Foot Operated w/Body Support

REVISION HISTORY TABLE

DATE	REVISION	CO#/ECO#	DETAILS
12/22/2015	A	CO-0066	Initial release

INSTALLATION

Backrest Installation (Model 326)

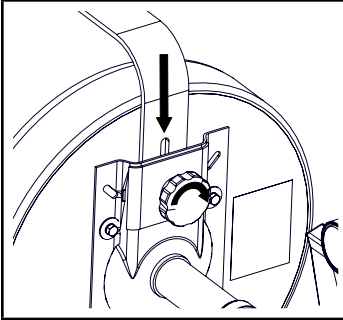

1. Insert the backrest into the bracket on the underside of the seat. Tighten in place with the knob.

Body Support Installation (Model 327)

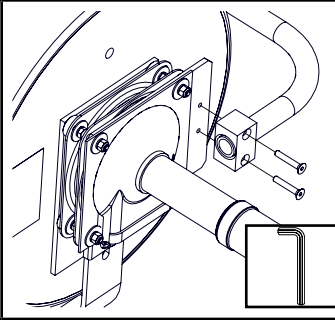

2. Attach the body support tube to the bracket on the underside of the seat with (2) 1-1/2" flat head screws using a 5/32" Allen wrench. Insert the rod of the ratchet assembly into the body support tube with the flat side towards the knob and tighten it into place.

Moving Body Support to Left Hand Side

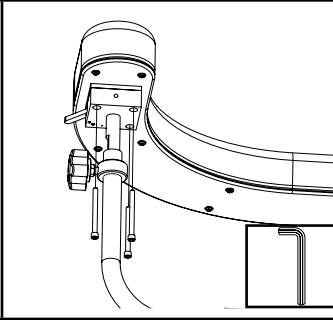

1. Remove the three bolts that secure the body support ratchet to the body support cushion using a 3/16" Allen wrench.

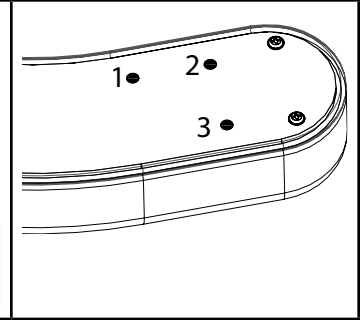

2. Feel for 3 holes hidden under upholstery on the opposite side of the body support cushion. Pierce 3 holes through the upholstery using a sharp instrument.

Moving Body Support to Left Hand Side

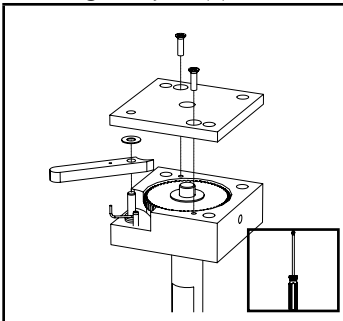

3. Remove the top plate of the ratchet assembly, held with two screws, using a phillips screwdriver. Remove the black plastic washer. (It may stick to the bottom of the top plate).

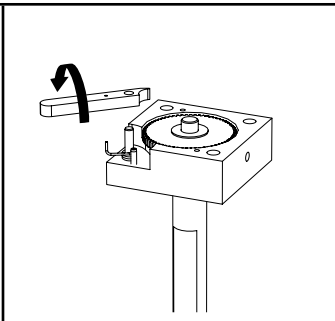

4. Flip the ratchet lever over and place it over the pin and verify the end of the spring is in the hole of the ratchet lever.

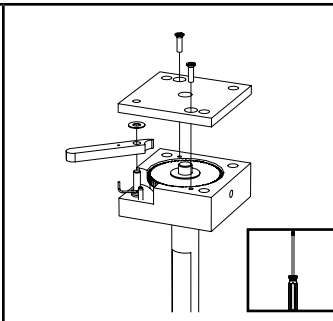

5. Place the black plastic washer over the pin and on top of the ratchet lever and reassemble the lid.

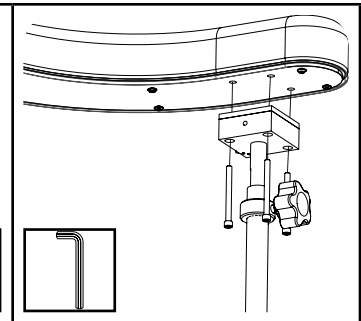

6. Reattach the body support ratchet using the 3/16" Allen wrench.

OPERATION

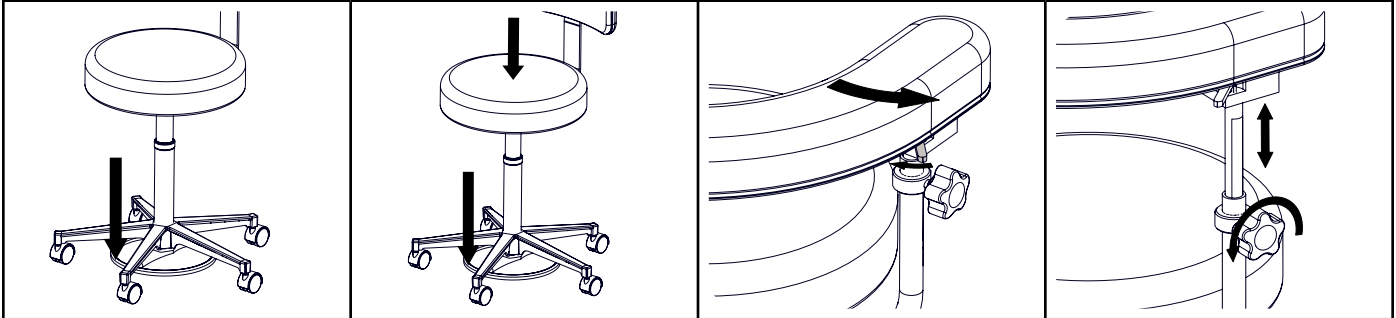

1. To raise the height of the stool, press down or lift up on the foot ring with no weight on the seat.

2. To lower the height of the stool, press down or lift up on the foot ring while placing weight on the seat.

3a. The body support will swivel towards the stool by pulling on the support.

3b. To move the support away from the stool, press the lever on the underside of the support towards the stool and move the support away.

4. To adjust the height of the body support, loosen the knob(s) on the side of the body support, adjust the height, and tighten the knob.

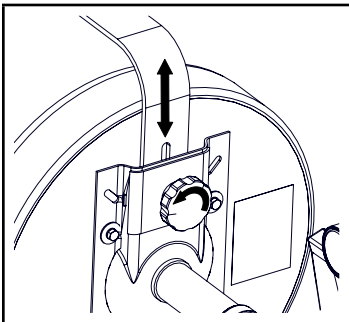

5. To adjust the position of the back, loosen the knob under the seat, slide the back in or out, and tighten the knob.

SPECIFICATIONS

DESCRIPTION	SPECIFICATION
Load Capacity	325: 250 lbs (113.4 kg) 326: 250 lbs (113.4 kg) 327: 225 lbs (102.1 kg)
Height of Stool	325/326: 18.5" to 23.75" (469.9 mm to 603.3 mm) 327: 19.5" to 24.75" (495.3 mm to 628.7 mm)
Weight of Stool	325: 18 lbs (8.2 kg) • 326: 23 lbs (10.4 kg) • 327: 36 lbs (16.3 kg)
Shipping Weight of Stool	325: 24 lbs (10.9 kg) • 326: 29 lbs (13.2 kg) • 327: 42 lbs (19.1 kg)
Shipping Size of Stool	25" x 25" x 25" (635 mm x 635 mm x 635 mm)

EXPLODED VIEWS

325-XX-XXX PNEUMATIC FOOT OPERATED STOOL W/O BACKREST

PART NUMBER	QTY	DESCRIPTION
033001A	4	HEX HEAD BOLT, 1/4-20 x 3/4 ZINC
038062	1	GAS SPRING, 5.27" FOOT OPERATED STOOL CYLINDER BLK
045148	4	LOCK WASHER, 1/4, ZINC
045171	4	FENDER WASHER, 1/4 x 1 ZINC
056001	5	CASTER, 2" HARD PLASTIC DUAL WHEEL BLACK
063001	1	BASE, 5 CASTER CHROME 50 MM
063003	1	ADPTR, FOOT OPERATED STOOL BASE
063005	1	COLUMN 6.64" CHROME TUBE F/5.27 STROKE
063006	1	PARTS PACK, f/FOOT OPERATED STOOLS
063006-1	1	RUBBER SLEEVE RETAINER
063006-2	1	TRIM
063006-3	1	RELEASE PIN
063006-4	1	SPRING
063006-5	3	SHOULDER BOLT, 5/16 X 1/2
063006-6	3	WASHER, FLAT 5/16
063009	1	RING, FOOT ACTUATOR
1009009-XX-XXX	1	ROUND SEAT ASSY, 16.5" DIA

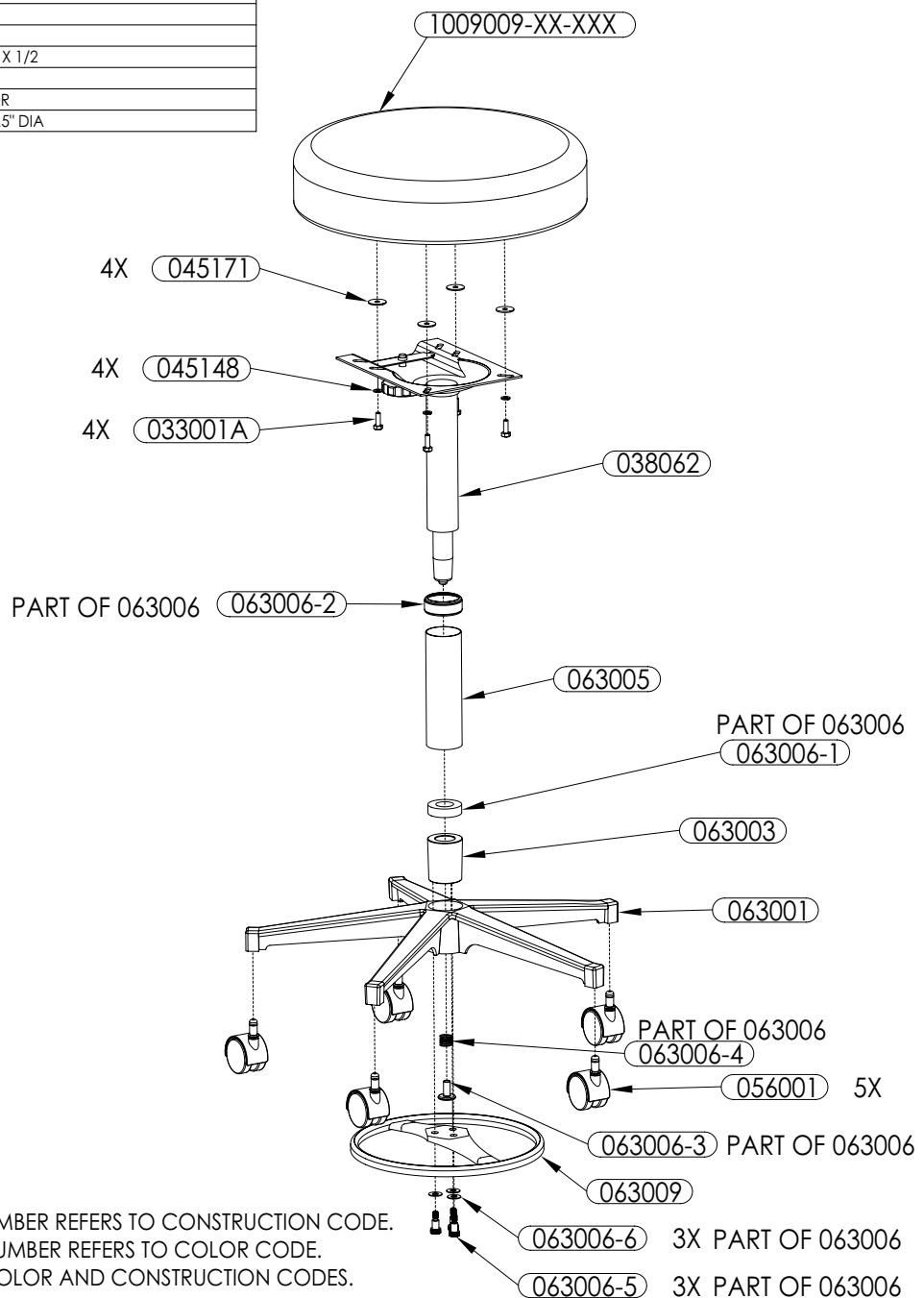

THE XX OF DRAWING/PART NUMBER REFERS TO CONSTRUCTION CODE.
 THE XXX OF DRAWING/PART NUMBER REFERS TO COLOR CODE.
 CONTACT MTI FOR SPECIFIC COLOR AND CONSTRUCTION CODES.

326-XX-XXX PNEUMATIC FOOT OPERATED STOOL W/ ERGO BACKREST

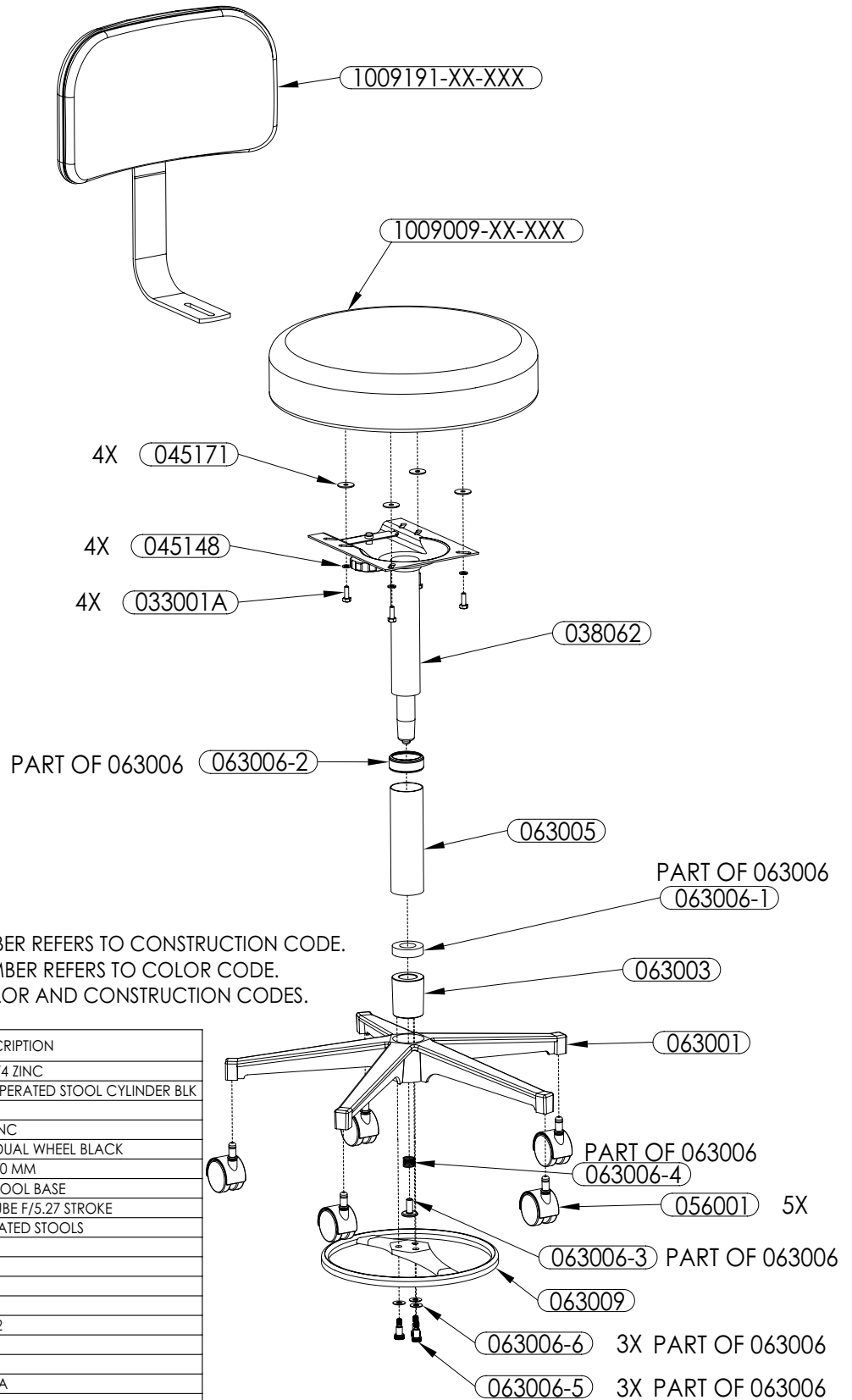

PART NUMBER	QTY	DESCRIPTION
033001A	4	HEX HEAD BOLT, 1/4-20 x 3/4 ZINC
038062	1	GAS SPRING, 5.27" FOOT OPERATED STOOL CYLINDER BLK
045148	4	LOCK WASHER, 1/4, ZINC
045171	4	FENDER WASHER, 1/4 x 1 ZINC
056001	5	CASTER, 2" HARD PLASTIC DUAL WHEEL BLACK
063001	1	BASE, 5 CASTER CHROME 50 MM
063003	1	ADPTR, FOOT OPERATED STOOL BASE
063005	1	COLUMN 6.64" CHROME TUBE F/5.27 STROKE
063006	1	PARTS PACK, f/FOOT OPERATED STOOLS
063006-1	1	RUBBER SLEEVE RETAINER
063006-2	1	TRIM
063006-3	1	RELEASE PIN
063006-4	1	SPRING
063006-5	3	SHOULDER BOLT, 5/16 X 1/2
063006-6	3	WASHER, FLAT 5/16
063009	1	RING, FOOT ACTUATOR
1009009-XX-XXX	1	ROUND SEAT ASSY, 16.5" DIA
1009191-XX-XXX	1	ERGO BACK ASSY

327-XX-XXX PNEUMATIC FOOT OPERATED STOOL W/ BODY SUPPORT

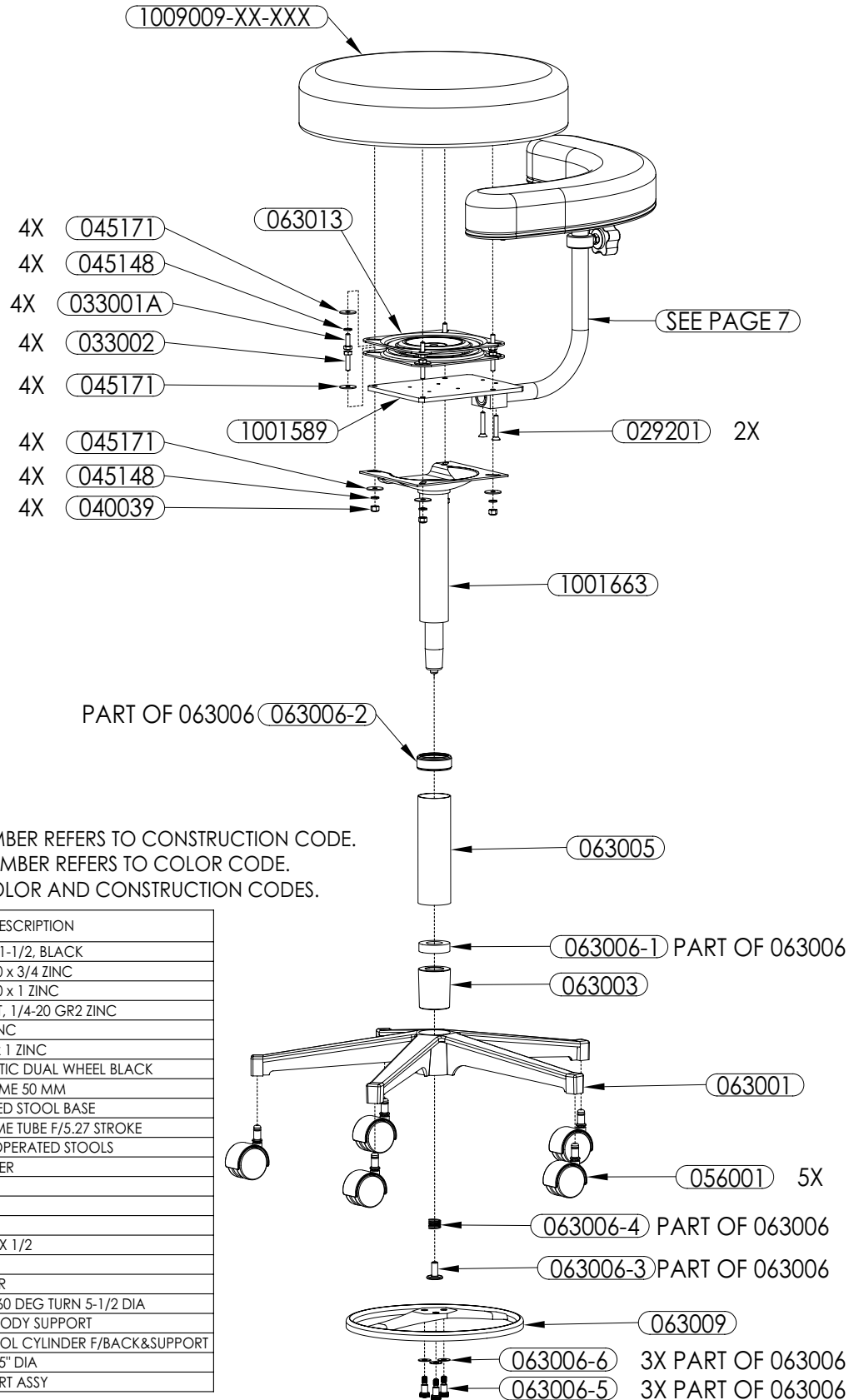

PART NUMBER	QTY	DESCRIPTION
029201	2	FHC SCREW, 1/4-20 X 1-1/2, BLACK
033001A	4	HEX HEAD BOLT, 1/4-20 x 3/4 ZINC
033002	4	HEX HEAD BOLT, 1/4-20 x 1 ZINC
040039	4	NYLON INSERT HEX NUT, 1/4-20 GR2 ZINC
045148	8	LOCK WASHER, 1/4, ZINC
045171	12	FENDER WASHER, 1/4 x 1 ZINC
056001	5	CASTER, 2" HARD PLASTIC DUAL WHEEL BLACK
063001	1	BASE, 5 CASTER CHROME 50 MM
063003	1	ADPTR, FOOT OPERATED STOOL BASE
063005	1	COLUMN 6.64" CHROME TUBE F/5.27 STROKE
063006	1	PARTS PACK, f/FOOT OPERATED STOOLS
063006-1	1	RUBBER SLEEVE RETAINER
063006-2	1	TRIM
063006-3	1	RELEASE PIN
063006-4	1	SPRING
063006-5	3	SHOULDER BOLT, 5/16 X 1/2
063006-6	3	WASHER, FLAT 5/16
063009	1	RING, FOOT ACTUATOR
063013	1	SWIVEL, STOOL SEAT 360 DEG TURN 5-1/2 DIA
1001589	1	MTG PLATE, CURVED BODY SUPPORT
1001663	1	GAS SPRING, 5.27" STOOL CYLINDER F/BACK&SUPPORT
1009009-XX-XXX	1	ROUND SEAT ASSY, 16.5" DIA
SEE PAGE 7	1	CURVED BODY SUPPORT ASSY

CURVED BODY SUPPORT ASSY

PART NUMBER	QTY	DESCRIPTION
1009200	1	TUBE WLD, BODY SUPPORT
1009198	1	BODY SUPPORT RATCHET ASSY
1009225-XX-XXX	1	BODY SUPPORT ARM ASSY
1009250	1	5-LOBE KNOB, 3/8-16 X .75 BLACK
029592A	3	SHC SCREW, 1/4-20 x 2-3/4 BLACK

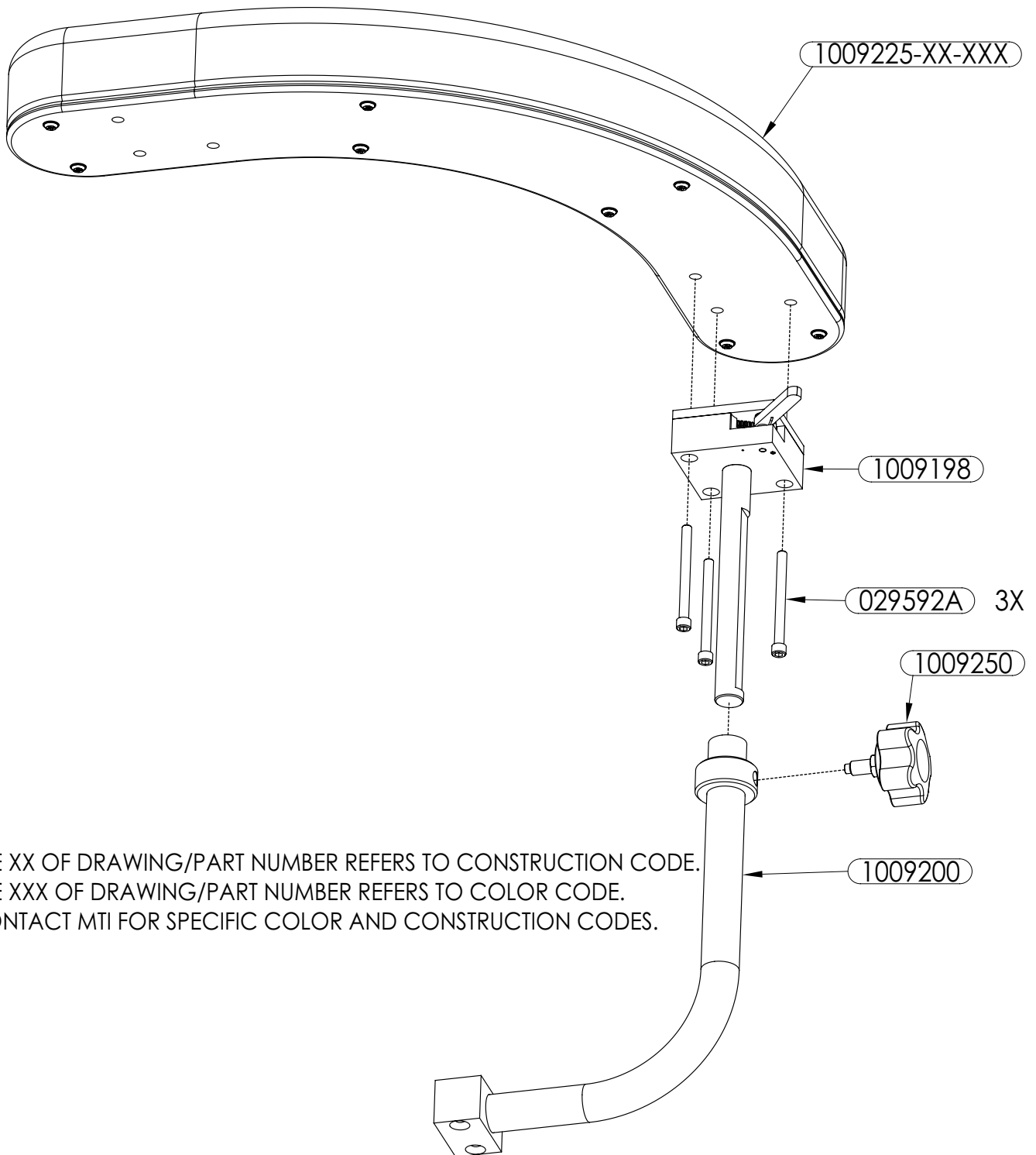

THE XX OF DRAWING/PART NUMBER REFERS TO CONSTRUCTION CODE.
 THE XXX OF DRAWING/PART NUMBER REFERS TO COLOR CODE.
 CONTACT MTI FOR SPECIFIC COLOR AND CONSTRUCTION CODES.

⚠️ WARNING/AVERTISSEMENT

No modification of this equipment is allowed.

Aucune modification de cet équipement est autorisée.

⚠️ WARNING/AVERTISSEMENT

Assure equipment, patient, and other objects are in safe condition before operating the equipment.

Assurer l'appareil, patient, et d'autres objets sont dans un état sûr avant d'utiliser l'appareil.

⚠️ WARNING/AVERTISSEMENT

This product contains chemicals known to the State of California to cause cancer and/or birth defects or other reproductive harm. See <http://www.mti.net/FAQs.aspx> for details on California Proposition 65.

Ce produit contient des produits chimiques reconnus par l'État de Californie pour causer le cancer et / ou des anomalies congénitales ou d'autres problèmes de reproduction. Voir <http://www.mti.net/FAQs.aspx> pour plus de détails sur la California Proposition 65.

Cleaning and Disinfection

See "MTI Cleaning Solution Recommendation Letter" for more details on disinfecting solutions which have been tested on MTI's products. It is available for download at <http://www.mti.net/downloads.aspx> in the Product Support Bulletins folder, found under the Resources tab on our website. In the U.S. & Canada, call (888) 520-4998, or International, call (801) 875-4998 to request a copy.

Painted and Plastic Surfaces

All painted metal parts have been electrostatically painted and the paint is baked on for durability. Weekly, those surfaces should be wiped down with a quality grade cleaner and a soft cloth or a damp cloth with mild soap.

Upholstery

Upholstery should be cleaned weekly with a mild liquid soap and water mixture. Afterwards, wipe upholstery with a clean damp cloth.

Calls for Service

(888) 520-4998 | International (801) 875-4998
customer.service@mti.net | www.mti.net

LIMITED WARRANTY

Medical Technology Industries, Inc. (hereinafter referred to as MTI), shall repair or replace products of its manufacture, which prove to be defective in material and/or workmanship for a period of twelve (12) months from the date of shipment to the customer (the "Warranty Period"). MTI will, at its option, provide parts to the customer or repair the defective part at MTI's factory or authorized repair facility. Except as it may otherwise specifically agree in writing, MTI shall not be liable for transportation or labor charges for repairs or adjustments or other work done on any of its products by MTI's authorized dealers or service organizations.

Customer shall notify MTI of any alleged claim or defect within fourteen (14) days from the date customer discovers, or upon reasonable inspection should have discovered, such alleged claim or defect (but in any event before the expiration of the Warranty Period). All repair parts are warranted for Ninety (90) calendar days from the date of shipment to the customer. Warranty is non-cumulative.

This warranty does not apply to any part or product which upon examination by MTI or its authorized agents indicates the product has been repaired or altered in any way by persons other than MTI or its authorized agents, has been misused, abused or used in a manner contrary to any instructions issued by MTI. Any parts or products claimed under this warranty must be properly packaged by customer and returned to MTI's factory with no liability to MTI for the parts, products or transportation charges thereon.

In no event, shall MTI have any liability for consequential, indirect, incidental, special, exemplary, punitive or enhanced damages, lost profits or diminution in value arising out of or relating to a product defect or the repair or replacement of any products manufactured or sold by it.

THE FOREGOING LIMITED WARRANTY IS MADE IN LIEU OF ALL WARRANTIES EXPRESSED OR IMPLIED, AND MTI MAKES NO OTHER WARRANTY WHATSOEVER WITH RESPECT TO THE PRODUCTS INCLUDING BUT NOT LIMITED TO, ANY IMPLIED WARRANTY OR MERCHANTABILITY OR FITNESS FOR A PARTICULAR PURPOSE.

